

EDGEKutter™: Just connect and kut rite to the edge

The final frontier of resurfacing existing floors continues to focus on problems with edging. How do you get close enough to the wall? How do you match the appearance of the edge with the rest of the floor? How do you eliminate working on your hands and knees with hand-held devices? How do you control the dust? For the answers to all of those questions – and a way to connect all the elements needed to gain a great edge – look no further than Kut-Rite Manufacturing's EDGEKutter™, an extension tool designed from the ground up to satisfy the contractor and finish a quality job.

The EDGEKutter™ is agile enough to allow the contractor to feel and control the edging operation as effectively as if he were down on the floor with a hand grinder. The device's tee-handle is ergonomically designed to allow the operator to use the machine from either side and can be adjusted in height for any operator's comfort. A second handle employs a throttle-style grip that controls the pitch of the attached grinder/polisher – giving the operator the same control that he would have with his hand grinder, only from a standing position.

The EDGEKutter™'s rocker pivot suspension at the rear axle helps the machine maneuver over undulations in the floor, achieving the same flatness on the edges that are obtained by the larger grinder/polisher in the central floor area. When powered up, the EDGEKutter™ floats in any direction and turns on a dime, guided by two non-marking swivel casters. The complete grinder and guidance mechanism is tucked away safely under the machine's cover, avoiding the feet of the operator during maneuvering.

The Kut-Rite EDGEKutter™ easily adapts to most brands of hand grinder or polisher and comes equipped with a state-of-the-art shroud and rubber dust seal with a front hook/loop-fastened flap that can be pulled off for extremely close edging. A vacuum hose mounts to the shroud's dust port and passes through a bracket/draw-latch assembly that keeps it (and the power cord) from getting in the way of the work.

While the EDGEKutter™ focuses on the edges of the floor, it is accurate enough to make touchups in field areas. In terms of safety, efficiency, accuracy and eliminating worker fatigue, this machine pays for itself many times over. The EDGEKutter™ grinder weighs 60 pounds; the polisher 55.

The EDGEKutter™ is offered as a stand-alone unit with grinder or polisher or in a complete system package with diamond cup wheel, MetalEDGE metal rings and/or a full set of EDGE-Kutter™ polishing rings and ceramic wheels. A complete system is also available with a KleanRite™ reverse-flow vacuum unit, ideally the RF21 version.



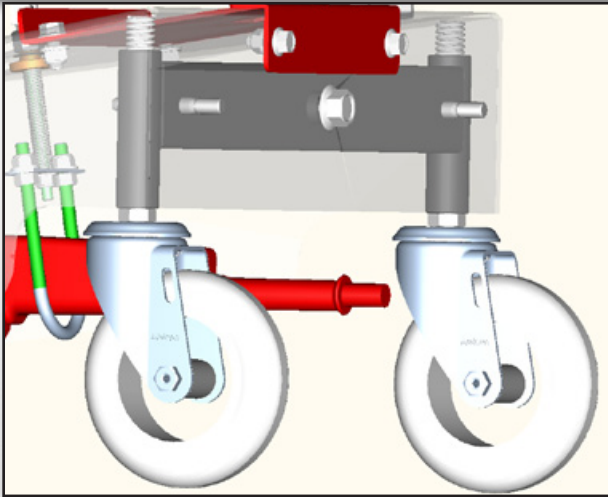

Rocker Pivot Suspension

The EDGEKutter™ floats over the surface gracefully creating a consistent scratch in the surface. The rocker pivot suspension enables the EDGEKutter™ to maneuver over undulations in the floor while maintaining flat and even contact between the abrasive wheel and the surface.

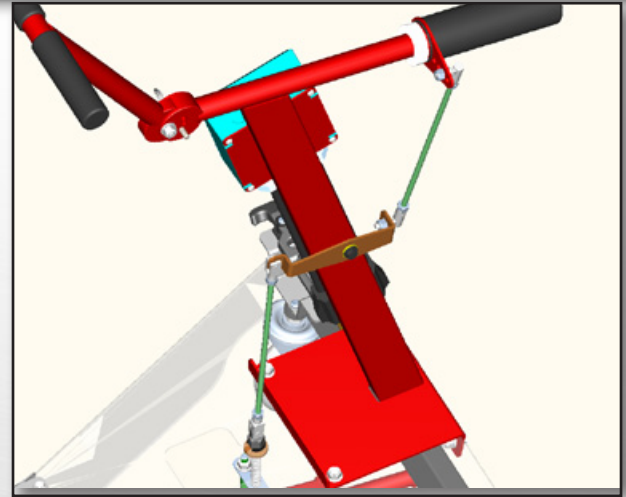

Tension Throttle

Adding the superior control is the unique spring loaded tension throttle that lifts the handle of the angle grinder/polisher and provides the control and feel required to grind, polish or sand.



Part Number	600000P	600000G
Model	EDGEKutter™ Grinder	EDGEKutter™ Polisher
Power	115V 6K RPM	115V 1750 VS
Grinding Path	7"	7"
Weight	60lbs	55lbs
Water System	None	None



Kut-Rite
No matter how you kut it.

27456 Northline
Romulus, MI 48174
www.kutritemfg.com